



## T45AU OPERATION MANUAL

**AUSTRALIAS LEADING MIST  
SYSTEM MANUFACTURER**



# CONTENTS

---

T45AU OVERVIEW

T45AU LAYOUT

BEFORE STARTING

AFTER USE & TRANSPORT

MAINTENANCE OIL

MAINTENANCE NOZZLES

SPARE PARTS

TROUBLESHOOTING

REMOTE OPERATION

WARRANTY

WIRING DIAGRAMS

RISK ASSESSMENT



OZMIST TOTAL CLIMATE SOLUTIONS  
26 ROWAN STREET  
WANGARATTA VICTORIA 3677  
PH; 1300 306 478  
E; INFO@OZMIST.COM.AU

·THE T45AU MIST CANNON HAS BEEN ASSEMBLED AND ALL FUNCTIONS TESTED IN OUR WORKSHOP. PLEASE ENSURE THAT THE UNIT IS CAREFULLY INSPECTED AFTER DELIVERY AS THINGS MAY HAVE CHANGED DURING TRANSPORT.

·EACH UNIT IS FITTED WITH A TRAVEL LATCH THAT NEEDS TO BE RELEASED BEFORE USE AND RE-ATTACHED BEFORE THE UNIT IS TRANSPORTED. IF YOUR UNIT HAS A TRAVEL PIN, SAME AS ABOVE MAKE SURE THE PIN IS REMOVED AND FITTED IN THE STORAGE HOLE DIRECTLY BELOW. THEN REINSTALLED BEFORE THE UNIT IS TRANSPORTED.

·THE FOG CANNON HAS A 2000L ALUMINIUM WATER TANK. THE TANK HAS A 3" CAMLOCK FILL POINT ON THE TOP OF THE TANK. A WATER-LEVEL GAUGE IS LOCATED BESIDE THE FILL POINT WHICH WILL SHOW THE TANK WATER LEVEL. THERE IS A 2" CAMLOCK FITTING ON THE LOWER CORNER OF THE UNIT FOR DRAINING THE SYSTEM.

A FLOAT SWITCH MONITORS THE WATER LEVELS, A RED LIGHT WILL ILLUMINATE ON THE OPERATIONS PANEL AND THE PUMP WILL TURN OFF WHEN WATER LEVELS GET TOO LOW.

·THE LARGE FAN ON TOP WILL THROW MIST OVER 45 METERS IN STILL CONDITIONS AND HAS THE ABILITY TO OSCILLATE LEFT TO RIGHT. THE CANNON CAN BE RAISED ALLOWING FOR ACCURATE TARGETING FOR THE MIST APPLICATION.

·A HIGH-PRESSURE PUMP OPERATES AT 1000PSI OR 70BAR AND MOVES 18 LITRES OF HIGH-PRESSURE MIST PER MINUTE. THE HIGH-PRESSURE PUMP IS INSTALLED IN THE TURRET BOX AND IS EASILY ACCESSIBLE FOR SERVICING. THIS PUMP IS SUPPLIED TANK WATER BY THE TRANSFER PUMP FITTED IN THE LOWER BOX IN THE REAR OF THE UNIT.

·DUAL FILTERS ARE FITTED TO THE SIDE OF THE TURRET BOX, EACH HOUSING CONTAINS ONE 10-MICRON AND ONE 5-MICRON FILTER. MAKING SURE TO CHECK THESE REGULARLY, ESPECIALLY IF WORKING WITH POOR WATER QUALITIES.

·POWER FOR THE ENTIRE UNIT COMES FROM THE FITTED 16KVA 3 PHASE MAKINEX GENERATOR WITH HONDA ELECTRIC START ENGINE. THE GENERATOR IS SECURED TO THE TOP OF THE TANK BY TWO RODS THAT LOCK IT DOWN INTO PLACE. THE GENERATOR IS EQUIPPED WITH 1 X 3PHASE PLUG AND 2 X 250V 15A PLUGS.

·THE MAIN CONTROL PANEL HAS SWITCHES TO CONTROL ALL OF THE ELECTRICAL FUNCTIONS OF THE SYSTEM. THE M45AU UNIT ALSO INCLUDES A FULLY FUNCTIONAL REMOTE CONTROL UNIT, THIS REMOTE CAN BE USED UP TO 100 METERS AWAY FROM THE CANNON.

·FLASHING LIGHTS ARE FITTED TO THE FRONT AND THE REAR OF THE TANK UNIT. THESE WILL ACTIVATE WHEN THE GENERATOR IS SWITCHED ON.



# THE T45AU IS CAPABLE OF THROWING MIST OVER 45 METERS

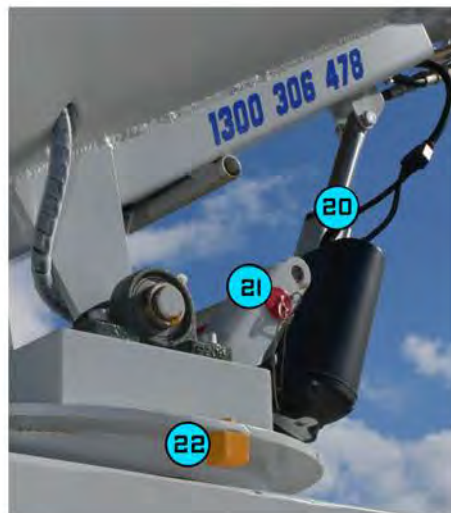
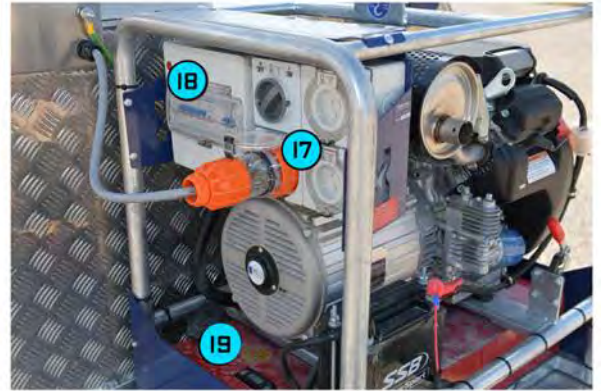
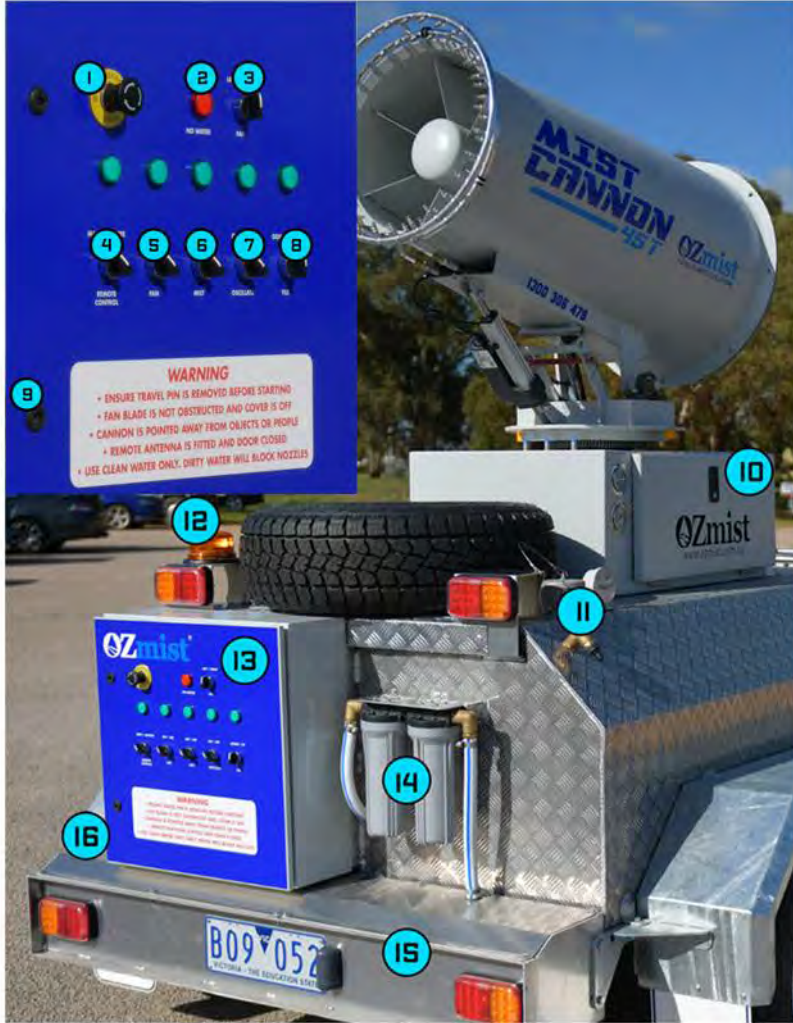

# ALWAYS ENSURE THE TRAVEL LATCH IS DISENGAGED BEFORE USE

---

1. STOP BUTTON
2. NO WATER SIGNAL LIGHT
3. MANUAL FAN ADJUST LEFT & RIGHT
4. REMOTE OR MANUAL OPERATION SWITCH
5. FAN ON/OFF SWITCH (GIVE 15SEC BEFORE TURN ON MIST)
6. MIST ON/OFF SWITCH
7. OSCILLATE ON/OFF SWITCH
8. MANUAL FAN ADJUST UP/DOWN
9. LOCK FOR OPERATIONS PANEL
10. TURRET BOX CONTAINING TRANSFER & HP PUMP
11. FILL POINTS (GAUGES NO LONGER FITTED TO CANNONS)
12. FLASHING SAFETY BEACONS
13. OPERATIONS PANEL
14. INLINE DUAL FILTER HOUSING
15. SCREEN FILTER & TRANSFER PUMP
16. 2" CAM-LOCK DRAIN POINT
17. 20A 3-PHASE POWER PLUG
18. GENERATOR POWER SWITCHBOARD
19. FUEL TANK (UNLEADED PETROL ONLY)
20. CANNON LIFT ACTUATOR
21. TRAVEL PIN IN THE UNLOCKED POSITION (OLD STYLE)
22. OSCILLATION LIMIT BLOCKS
23. REMOTE & ANTENNA
24. TRAVEL LATCH ENGAGED (NEW STYLE)
25. OSCILLATION PROXIMITY SENSORS

# ONLY EVER USE UNLEADED FUEL IN THE GENERATOR

---

## STARTUP PROCEDURE

BEFORE STARTING IT IS RECOMMENDED THAT YOU PERFORM A SAFETY CHECK NOT LIMITED TO THE FOLLOWING ITEMS:

- PLACE THE CANNON ON A FLAT SURFACE.
- DISENGAGE THE TRAVEL LATCH FROM THE UNDERSIDE OF THE CANNON.
- CHECK THAT THE FAN SPINS WITHOUT ANY OBSTRUCTION.
- CHECK THAT ALL 60 NOZZLES ARE IN PLACE AND FIRM.
- SLIDE THE HIGH-PRESSURE PUMP OUT OF THE TURRET BOX AND CHECK THE OIL LEVEL AS SHOWN BELOW.

## BEFORE STARTING

- CHECK FUEL LEVEL IN THE GENERATOR.
- ENSURE THAT THERE IS SUFFICIENT WATER IN THE TANK.
- IF YOU WISH TO USE THE REMOTE MAKE SURE THAT THE ANTENNA AND REMOTE HAVE BEEN REMOVED FROM THE CONTROL PANEL AND ARE IN GOOD CONDITION.
- ENSURE THAT THE 20A PLUG IS CONNECTED TO THE GENERATOR AND TURNED ON.

## STARTUP

- OPEN THE CHOKE ON THE GENERATOR AND TURN THE KEY. WHEN THE ENGINE STARTS CLOSE THE CHOKE.
- USE THE UP & DOWN SWITCH TO RAISE THE POSITION OF THE CANNON.
- USE THE LEFT & RIGHT SWITCH TO MANUALLY POSITION THE CANNON.
- SWITCH THE FAN ON AND WAIT APPROX 15 SECONDS FOR THE FAN TO WIND UP TO FULL SPEED.
- TURN THE MIST SWITCH TO ITS ON POSITION.
- ONCE YOU HAVE MIST OBSERVE THE MISTING RING TO CHECK THAT EACH NOZZLE IS MISTING.
- NOW THAT THE M45AU IS OPERATING YOU CAN CHOOSE TO EITHER TARGET THE CANNON MANUALLY USING THE FAN UP/DOWN/LEFT/RIGHT OR SET THE CANNON TO OSCILLATE AUTOMATICALLY.
- TO USE THE REMOTE CONTROL FIND THE REMOTE SWITCH ON THE CONTROL PANEL AND TOGGLE THIS FROM MANUAL TO REMOTE. YOU WILL SEE THE GREEN LIGHT ILLUMINATE. YOU CAN NOT CONTROL THE CANNON FROM THE REMOTE CONTROL AT UP TO 100 METERS AWAY.

## AFTER USE & TRANSPORT

---

OUR CANNONS ARE INCREDIBLY EASY TO MOVE TO AND FROM OR AROUND THE WORKSITE. IT IS IMPORTANT TO FOLLOW THESE STEPS WHEN YOU ARE PACKING DOWN YOUR MACHINE AFTER OPERATING. THIS WILL ENSURE THAT YOUR MACHINE IS READY TO BE USED DAY IN DAY OUT.

### AFTER USE PROCEDURE

- CENTRE THE CANNON OVER THE GENERATOR AND MAKE SURE THAT THE CANNON IS LOWERED ALL THE WAY DOWN INTO ITS CRADLE.
- ENGAGE THE TRAVEL LATCH SO THAT THERE CAN BE NO MOVEMENT THROUGH THE CANNON.
- ACTIVATE THE STOP BUTTON ON THE CONTROL PANEL.
- ON THE GENERATOR YOU WILL SWITCH OFF THE MAIN POWER SUPPLY AND REMOVE THE PLUG. IF STORING THE MACHINE FOR LONG PERIODS PLEASE SWITCH THE CIRCUIT BREAKERS TO OFF.
- ONCE THE GENERATOR IS OFF AND DISCONNECTED YOU CAN OPEN THE CONTROL PANEL AND STORE THE REMOTE CONTROL AND ANTENNA IF THEY HAVE BEEN USED.
- IF THE MACHINE IS NOT GETTING USED FOR A LONG DURATION IT IS BEST TO DRAIN THE TANK, IF TRAVELLING A LONG DISTANCE, AVOID TRAVELLING WITH AN ULLAGE.

### TRANSPORTING

- THE T45AU SHOULD BE TREATED LIKE ANY TRAILER. MAKE SURE THE HANDBRAKE IS DISENGAGED, THE JOCKEY WHEEL IS RETRACTED AND ROTATED, THE TRAILER IS SECURED WITH THE SAFETY CHAINS AND THE 7-PIN PLUG IS CORRECTLY CONNECTED TO THE VEHICLE.
- THE M45AU UNIT MEASURES 1900MM X 1200MM IN LENGTH AND WIDTH MAKING IT PRACTICAL TO CARRY ON MOST TRUCKS AND UTEs.
- IF TRANSPORTING THE M45AU ON THE BACK OF A UTE OR TRUCK, MAKE SURE THAT THE LOAD IS SECURED WITH LOAD RATED STRAPS. RATCHET STRAPS CAN BE RUN ACROSS THE TOP OF THE TURRET BOX, DO THIS WITH CAUTION AND KEEP AWAY FROM THE PROXIMITY SENSORS. DO NOT RUN STRAPS OVER THE CONTROL PANEL.
- DOUBLE-CHECK THAT THE CANNON HAS BEEN LOWERED INTO ITS CRADLE AND THAT THE TRAVEL LATCH IS ENGAGED.
- IF THE MACHINE IS BEING TRANSPORTED ON UTE OR OPEN-AIR TRUCK IT IS A GOOD IDEA TO COVER THE CANNON TO PROTECT FROM BUGS AND OTHER ELEMENTS WHILE TRANSPORTING.





## MAINTENANCE - OIL

---

THE OZMIST T45AU MIST CANNON FEATURES ONE OF OZMIST'S RENOWNED INDUSTRIAL PUMP UNITS, CAPABLE OF PRESSURISING 18 LITRES OF WATER PER MINUTE AT 1000PSI OR 70 BAR. OUR PUMPS ARE KNOWN FOR THEIR RELIABILITY AND PERFORMANCE AND WILL KEEP YOU RUNNING FOR YEARS TO COME. BUT LIKE EVERY PUMP IT NEEDS TO TO BE PROPERLY MAINTAINED.

THESE PUMPS NEED AN OIL CHANGE EVERY 500 HOURS OF OPERATION. YOU SHOULD ALSO CHECK THE OIL REGULARLY TO ENSURE THAT THE OIL IS AT THE CORRECT LEVEL.

### CHECKING THE OIL

- UNDO THE CATCH ON THE TURRET DOOR AND LOWER THE LID.
- ONCE OPEN, REMOVE THE PIN THAT STOPS THE HIGH-PRESSURE PUMP FROM SLIDING OUT ON ITS RAILS.
- WHEN REMOVED, SLIDE THE PUMP OUT ON ITS RAILS SO YOU CAN REACH THE SILVER CANISTER ON THE TOP OF THE PUMP.
- UNSCREW THE CAP ON THE SILVER CANISTER AND CHECK THE OIL LEVEL. THE OIL LEVEL SHOULD BE HALFWAY UP THE SILVER CANISTER. IF BELOW PLEASE TOP UP WITH 10W - 50 FULLY SYNTHETIC OIL.

### CHANGING THE OIL

- AS ABOVE, REMOVE THE PIN AND SLIDE THE PUMP OUT ON ITS RAILS UNTIL YOU CAN LOCATE THE BRASS OIL DRAIN PLUG ON THE UNDERSIDE OF THE PUMP UNIT.
- PLACE A SUITABLE CONTAINER UNDER THE PUMP TO CATCH THE OIL.
- REMOVE THE DRAIN PLUG AND OIL SHOULD FLOW FROM THE PUMP INTO YOUR CONTAINER, WHILE DRAINING REMOVE THE CAP FROM THE TOP OF THE SILVER CANISTER AND STORE SOMEPLACE SAFE.
- ONCE THE PUMP HAS DRAINED ALL ITS OIL YOU CAN REPLACE THE DRAIN PLUG AND TIGHTEN IT FIRMLY.
- PROCEED TO FILL THE PUMP FROM THE SILVER CANISTER POURING OIL VERY SLOWLY, ALLOWING AIR TO DISSIPATE. POUR UNTIL THERE IS OIL HALFWAY UP THE SILVER CANISTER.

IT IS GOOD PRACTICE TO RUN THE PUMP FOR A SHORT AMOUNT OF TIME AFTER AN OIL CHANGE. ONCE RUN FOR A SHORT TIME CHECK THE OIL LEVEL AGAIN.

ONLY USE 10W - 40 OR 10W - 50 FULLY SYNTHETIC OIL IN OUR PUMPS.

PLEASE REFERENCE THE MAKINEX GENERATOR USER MANUAL THAT IS SUPPLIED WITH EVERY MIST CANNON TO FIND THEIR RECOMMENDED SERVICE INTERVALS.





---

## DO NOT ADJUST NOZZLES WHILE THE MACHINE IS OPERATIONAL

---

### NOZZLES

EACH CANNON IS FITTED WITH 60 HIGH PRESSURE MISTING NOZZLES. IT IS IMPORTANT TO VISUALLY INSPECT THESE NOZZLES PERIODICALLY TO CHECK FOR BLOCKAGES. IF YOU HAVE A BLOCKED NOZZLE, SHUT DOWN THE UNIT AND ONCE STOPPED REMOVE THE FACE OF THE BLOCKED NOZZLES (SHOWN IN IMAGE) BEING CAREFUL NOT TO LOSE ANY OF THE SMALL COMPONENTS THAT ARE SEATED INSIDE.

WASH THE BLOCKED NOZZLE FACE IN CLEAN WATER. IT IS ALSO POSSIBLE TO SOAK THE NOZZLE FACE IN PRODUCTS SUCH AS CLR CLEAR TO REMOVE ANY CALCIUM BUILD-UP.



### WATER FILTRATION

THERE ARE TWO INLINE 10" CARTRIDGE FILTERS INSTALLED ON THE INSIDE EDGE OF THE TURRET BOX. THE FILTER CLOSEST TO THE WATER INLET IS A 10-MICRON FILTER WITH THE NEXT BEING A 5-MICRON FILTER. THESE SHOULD BE CHECKED REGULARLY AS A BLOCKED FILTER CAN CAUSE ISSUES WITH THE HIGH-PRESSURE PUMP CAUSING DOWNTIME WITH THE MACHINE. OUR FILTERS CAN BE PURCHASED FROM MOST PLUMBING SUPPLY STORES.

EVERY MIST CANNON PURCHASED IS SUPPLIED WITH THE APPROPRIATE TOOLING TO REMOVE AND REPLACE THE FILTERS ON THE SPECIFIC MACHINE.

THE T45AU IS ALSO FITTED WITH A SCREEN FILTER THAT CAN BE BACKFLUSHED IF REQUIRED. THIS SCREEN FILTER IS FITTED IN THE STEP ON THE REAR OF THE MACHINE DIRECTLY BELOW THE DUAL FILTER HOUSINGS.

KEEP IN MIND THAT RUNNING A MACHINE WITH DIRTY FILTERS CAN ALLOW DIRT TO TRAVEL THROUGH THE SYSTEM AND END UP IN THE NOZZLES, ESPECIALLY IF YOU ARE DRAWING FROM A POOR QUALITY WATER SOURCE.



---

## KEEP YOUR SPARE PARTS IN A SAFE AND DRY LOCATION

---

THERE IS A NUMBER OF SPARE PARTS THAT ARE PROVIDED IN A TOOLBOX WHEN YOU PURCHASE ONE OF OUR MOBILE MIST CANNONS. THIS TOOLBOX WILL ALSO HOUSE ALL THE DOCUMENTATION NEEDED FOR MACHINE OPERATION.

THESE SPARES INCLUDE CONSUMABLE PRODUCTS SUCH AS:

- REPLACEMENT 5 & 10-MICRON CARTRIDGE FILTERS
- REPLACEMENT 0.5MM HIGH-PRESSURE MISTING NOZZLES
- A 1-LITRE BOTTLE OF 10W-50 FULLY SYNTHETIC OIL

YOU WILL ALSO RECEIVE COMPONENTS AND TOOLS IN THE SPARE PARTS BOX:

- OSCILLATION BLOCKS FOR LIMITING THE MACHINES LEFT & RIGHT ROTATION
- PLASTIC SPANNER FOR REMOVING FILTER HOUSING FOR INSPECTION AND REPLACEMENT
- KEY TO UNLOCK THE OPERATIONS PANEL DOOR



## TROUBLESHOOTING

<p>GENERATOR IS RUNNING BUT FAN WILL NOT START?</p>	<ul style="list-style-type: none"><li>• CHECK THE POWER CABLE IS CONNECTED TO THE GENERATOR.</li><li>• CHECK THE MAIN POWER SWITCH IS IN ITS 'ON' POSITION ON THE GENERATOR.</li><li>• POWER SUPPLY CIRCUIT COULD BE OVERLOADED AND TRIPPED ON THE GENERATOR.</li><li>• CHECK THE WATER LEVEL IN THE TANK, THE WATER LIGHT ON THE CONTROL PANEL SHOULD BE ILLUMINATED.</li><li>• TURN OFF THE GENERATOR AND HAVE QUALIFIED PERSONS CHECK THE SAFETY SWITCH INSIDE THE CONTROL PANEL.</li></ul>
<p>CANNON WILL NOT TILT UP FROM ITS HOMED POSITION?</p>	<ul style="list-style-type: none"><li>• CHECK THAT THERE IS POWER, THE GREEN LIGHT ON THE CONTROL BOARD SHOULD BE ILLUMINATED.</li><li>• CHECK THAT THE STOP BUTTON IS DISENGAGED.</li><li>• CHECK THAT THE CIRCUIT BREAKER HAS NOT BEEN TRIPPED ON THE GENERATOR.</li><li>• TURN THE GENERATOR OFF AND HAVE QUALIFIED PERSONS CHECK THE CIRCUIT BREAKER INSIDE THE CONTROL PANEL.</li><li>• IF THE CANNON HAS BEEN RAISED SLIGHTLY WITH THE TRAVEL LATCH IN ITS LOCKED POSITION THERE WILL BE PRESSURE ON THE LATCH AND IT WILL NOT UNDO, WITH THE MACHINE RUNNING HOLD THE DOWN SWITCH UNTIL THE LATCH CAN BE SAFELY UNDONE.</li></ul>
<p>MIST CANNON NOT GIVING A CONSISTANT MIST OUTPUT</p>	<ul style="list-style-type: none"><li>• THIS USUALLY OCCURS WHEN THE FILTERS ARE DIRTY OR BLOCKED SEE THE "MAINTENANCE PAGE" THAT REFERS TO FILTRATION CARE AND REPLACEMENT.</li></ul>

IF YOU HAVE AN ISSUE WITH YOUR M45AU MIST CANNON PLEASE CONTACT



26 ROWAN STREET  
WANGARATTA VICTORIA 3677  
INFO@OZMIST.COM.AU  
1300 306 478  
WWW.OZMIST.COM.AU



# REMOTE OPERATION



## REMOTE FUNCTIONS

1. REMOTE ON BUTTON
2. REMOTE OFF BUTTON
3. FAN ON / OFF BUTTON
4. MIST ON / OFF BUTTON
5. CANNON UP BUTTON
6. CANNON DOWN BUTTON
7. OSCILLATE ON / OFF BUTTON
8. N/A
9. ANTENNA

**\*MAKE SURE THAT THE ANTENNA IS STUCK TO THE SIDE NOT THE TOP OF THE OPERATIONS BOX. THIS WILL ALLOW WATER TO DRIP OFF THE ANTENNA AND NOT INTO THE BOX.**

## CONTACT DETAILS

# INFO@OZMIST.COM.AU - 1300 306 478

---

OZMIST

### LIMITED WARRANTY AGAINST DEFECTS POLICY

THIS DOCUMENT SETS THE LIMITED WARRANTY AGAINST DEFECTS FOR CERTAIN PRODUCTS MANUFACTURED BY OZ MIST PTY LTD ACN 096 811 488 (REFERRED TO IN THESE TERMS AND CONDITIONS AS 'OZMIST', 'WE', 'US', OR 'OUR'). A PERSON OR ORGANISATION WHO HAS PURCHASED AN OZMIST PRODUCT WILL BE REFERRED TO IN THIS DOCUMENT AS 'YOU' OR 'YOUR'.

OZMIST WARRANTS THAT THE PRODUCTS THAT IT SELLS DIRECTLY TO YOU ARE FREE FROM DEFECTS IN WORKMANSHIP. OUR PRODUCTS ARE PUT THROUGH TESTS AND INSPECTIONS BEFORE THEY ARE SOLD TO YOU. IF WITHIN THE WARRANTY PERIOD DEFINED BELOW, YOU BELIEVE A PRODUCT YOU HAVE PURCHASED FROM US DOES NOT COMPLY WITH THIS WARRANTY, THEN YOU MUST FOLLOW THE PROCESS SET OUT IN THIS WARRANTY DOCUMENT.

#### 1. AUSTRALIAN CONSUMER LAW DISCLAIMER

OUR GOODS AND SERVICES COME WITH GUARANTEES THAT CANNOT BE EXCLUDED UNDER THE AUSTRALIAN CONSUMER LAW. YOU ARE ENTITLED TO A REPLACEMENT OR REFUND FOR A MAJOR FAILURE AND COMPENSATION FOR ANY OTHER REASONABLY FORESEEABLE LOSS OR DAMAGE. YOU ARE ALSO ENTITLED TO HAVE THE GOODS REPAIRED OR REPLACED IF THE GOODS FAIL TO BE OF ACCEPTABLE QUALITY AND THE FAILURE DOES NOT AMOUNT TO A MAJOR FAILURE. THIS WARRANTY IS IN ADDITION TO YOUR RIGHTS UNDER THE AUSTRALIAN CONSUMER LAW.

#### 2. WHAT THE WARRANTY COVERS

THIS WARRANTY APPLIES:

1. TO ANY OZMIST PRODUCTS, INCLUDING PARTS OF A PRODUCT, EXCEPT AS EXCLUDED IN CLAUSE 3 (PRODUCT); AND
2. FOR 1 YEAR FROM THE DATE YOU PURCHASED THE PRODUCT FROM US (WARRANTY PERIOD).

#### 3. EXCLUSIONS

THIS WARRANTY DOES NOT COVER ANY CONSUMABLES, INCLUDING BUT NOT LIMITED TO NOZZLES, PUMPS, INTERNAL SEALS, WATER FILTERS, NYLON TUBES AND SIMILAR COMPONENTS OF A PRODUCT.

THIS WARRANTY ALSO DOES NOT COVER ANY DEFECT WHICH IS A RESULT OF YOUR OR ANOTHER PARTYS FAULT, INCLUDING BUT NOT LIMITED TO:

- FAILURE TO PROPERLY INSTALL THE PRODUCT IN ACCORDANCE WITH OUR INSTRUCTION MANUALS;
- FAILURE TO USE THE PRODUCTS IN ACCORDANCE WITH OUR INSTRUCTION MANUALS;
- EXPOSURE TO CONDITIONS DUE TO THE MANNER IN WHICH THE PRODUCT IS INSTALLED, USED OR STORED;
- POWER SUPPLY ISSUES THAT AFFECT THE INSTALLATION OR USE OF THE PRODUCT;
- FAILURE TO STORE THE PRODUCT IN A SECURE FACILITY;
- MODIFICATION OR MISUSE OF THE PRODUCT;
- REGULAR WEAR AND TEAR;

## CONTACT DETAILS

### INFO@OZMIST.COM.AU - 1300 306 478

---

#### 4. HOW TO MAKE A CLAIM UNDER THIS WARRANTY

##### 1. MAKING A CLAIM

IF WITHIN THE WARRANTY PERIOD, YOU BELIEVE THAT A PRODUCT YOU PURCHASED IS FAULTY, YOU MUST IMMEDIATELY STOP USING THE PRODUCT AND PLEASE CONTACT US BY USING THE EMAIL ADDRESS PROVIDED IN THE HEADER OF THIS WARRANTY DOCUMENT WITH FULL DETAILS OF THE FAULT (INCLUDING IMAGES).

##### 2. FURTHER INSPECTION

IF WE DETERMINE THAT YOUR PRODUCT MAY BE DEFECTIVE, WE WILL EITHER;

1. REQUEST THAT YOU SEND YOUR PRODUCT (OR A PART OF A PRODUCT, SUCH AS THE MOTOR) BACK TO US, AT YOUR COST, FOR FURTHER INSPECTION USING OUR OWN TESTING METHODS, INCLUDING ANY REQUESTED ACCESSORIES, DOCUMENTATION OR REGISTRATION SHIPPED WITH THE PRODUCT. OR;
2. IF YOUR PRODUCT IS LOCATED WITHIN A REASONABLE DISTANCE OF OUR BUSINESS ADDRESS PROVIDED IN THE HEADER OF THIS WARRANTY DOCUMENT (PRODUCT LOCATION), WE MAY, AT OUR ABSOLUTE DISCRETION, VISIT THE PRODUCT LOCATION FOR FURTHER INSPECTION OR TO PICK UP THE PRODUCT FOR REPAIRS, WITHIN A REASONABLE TIME NOTIFIED BY US TO YOU. IF WE CHOOSE TO DO THIS, WE WILL COMMUNICATE TO YOU THE DATE/S AND TIME/S WE WILL TRAVEL TO THE PRODUCT LOCATION AND YOU MUST ENSURE THAT YOU OR A REPRESENTATIVE IS AVAILABLE AT THOSE DATES AND TIMES.

##### 3. AFTER INSPECTION

IF WE DETERMINE, IN OUR ABSOLUTE DISCRETION;

1. THAT THE RELEVANT PRODUCT IS FAULTY AND COVERED BY THIS WARRANTY, WE WILL PROVIDE YOU WITH A REPAIR, REPLACEMENT OR REFUND OF THE PRODUCT AT OUR COST. OR;
2. THAT THE RELEVANT PRODUCT IS NOT FAULTY OR IS FAULTY DUE TO YOUR FAULT OR ANY EXCLUSIONS SET OUT IN CLAUSE 3, WE WILL REFUSE YOUR WARRANTY CLAIM.

#### 4. NO OTHER WARRANTIES

TO THE MAXIMUM EXTENT PERMITTED BY APPLICABLE LAW, ALL EXPRESS OR IMPLIED REPRESENTATIONS AND WARRANTIES NOT EXPRESSLY STATED IN THIS WARRANTY DOCUMENT, OR IN ANY WRITTEN TERMS AND CONDITIONS ISSUED BY US, ARE EXCLUDED.

##### 5. LIABILITY

TO THE MAXIMUM EXTENT PERMITTED BY LAW, WE EXCLUDE ANY LIABILITY THAT MAY ARISE AS A RESULT OF YOU PURSUING A WARRANTY CLAIM IN ACCORDANCE WITH THIS WARRANTY DOCUMENT.

##### 6. JURISDICTION

THIS WARRANTY DOCUMENT IS GOVERNED BY THE LAWS OF VICTORIA, AUSTRALIA.





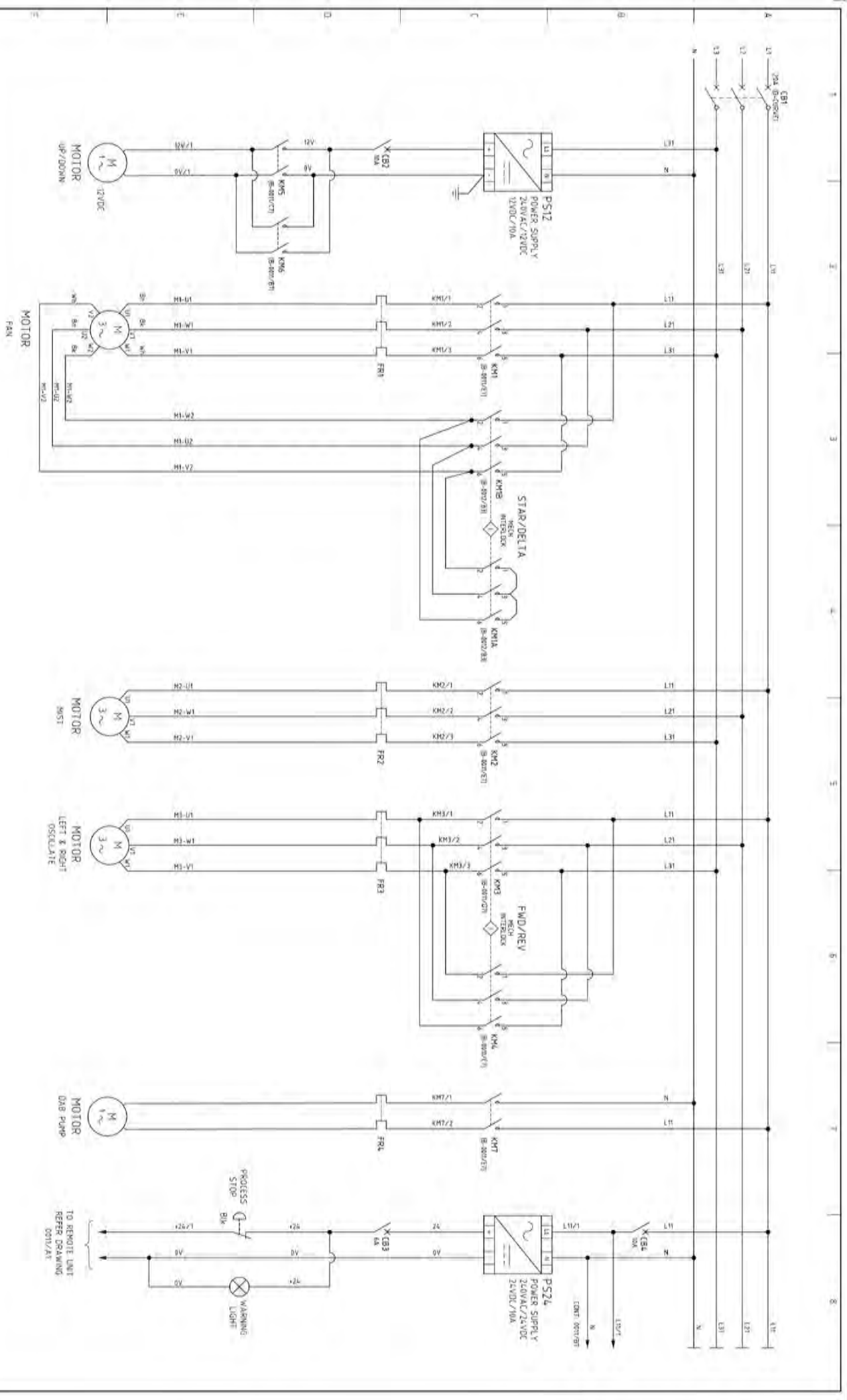

1	24V AC/50Hz	CB1	
2	24V DC	PS12	
3	24V AC/50Hz	PS24	
4	12V DC	M1	
5	24V AC/50Hz	M2	
6	24V AC/50Hz	M3	
7	24V AC/50Hz	M4	
8	12V DC	FR1	
9	24V AC/50Hz	FR2	
10	24V AC/50Hz	FR3	
11	24V AC/50Hz	FR4	
12	24V AC/50Hz	FR5	
13	24V AC/50Hz	FR6	
14	24V AC/50Hz	FR7	
15	24V AC/50Hz	CB2	
16	24V AC/50Hz	CB3	
17	24V AC/50Hz	CB4	
18	24V AC/50Hz	CB5	
19	24V AC/50Hz	CB6	
20	24V AC/50Hz	CB7	
21	24V AC/50Hz	CB8	
22	24V AC/50Hz	CB9	
23	24V AC/50Hz	CB10	
24	24V AC/50Hz	CB11	
25	24V AC/50Hz	CB12	
26	24V AC/50Hz	CB13	
27	24V AC/50Hz	CB14	
28	24V AC/50Hz	CB15	
29	24V AC/50Hz	CB16	
30	24V AC/50Hz	CB17	
31	24V AC/50Hz	CB18	
32	24V AC/50Hz	CB19	
33	24V AC/50Hz	CB20	
34	24V AC/50Hz	CB21	
35	24V AC/50Hz	CB22	
36	24V AC/50Hz	CB23	
37	24V AC/50Hz	CB24	
38	24V AC/50Hz	CB25	
39	24V AC/50Hz	CB26	
40	24V AC/50Hz	CB27	
41	24V AC/50Hz	CB28	
42	24V AC/50Hz	CB29	
43	24V AC/50Hz	CB30	
44	24V AC/50Hz	CB31	
45	24V AC/50Hz	CB32	
46	24V AC/50Hz	CB33	
47	24V AC/50Hz	CB34	
48	24V AC/50Hz	CB35	
49	24V AC/50Hz	CB36	
50	24V AC/50Hz	CB37	
51	24V AC/50Hz	CB38	
52	24V AC/50Hz	CB39	
53	24V AC/50Hz	CB40	
54	24V AC/50Hz	CB41	
55	24V AC/50Hz	CB42	
56	24V AC/50Hz	CB43	
57	24V AC/50Hz	CB44	
58	24V AC/50Hz	CB45	
59	24V AC/50Hz	CB46	
60	24V AC/50Hz	CB47	
61	24V AC/50Hz	CB48	
62	24V AC/50Hz	CB49	
63	24V AC/50Hz	CB50	
64	24V AC/50Hz	CB51	
65	24V AC/50Hz	CB52	
66	24V AC/50Hz	CB53	
67	24V AC/50Hz	CB54	
68	24V AC/50Hz	CB55	
69	24V AC/50Hz	CB56	
70	24V AC/50Hz	CB57	
71	24V AC/50Hz	CB58	
72	24V AC/50Hz	CB59	
73	24V AC/50Hz	CB60	
74	24V AC/50Hz	CB61	
75	24V AC/50Hz	CB62	
76	24V AC/50Hz	CB63	
77	24V AC/50Hz	CB64	
78	24V AC/50Hz	CB65	
79	24V AC/50Hz	CB66	
80	24V AC/50Hz	CB67	
81	24V AC/50Hz	CB68	
82	24V AC/50Hz	CB69	
83	24V AC/50Hz	CB70	
84	24V AC/50Hz	CB71	
85	24V AC/50Hz	CB72	
86	24V AC/50Hz	CB73	
87	24V AC/50Hz	CB74	
88	24V AC/50Hz	CB75	
89	24V AC/50Hz	CB76	
90	24V AC/50Hz	CB77	
91	24V AC/50Hz	CB78	
92	24V AC/50Hz	CB79	
93	24V AC/50Hz	CB80	
94	24V AC/50Hz	CB81	
95	24V AC/50Hz	CB82	
96	24V AC/50Hz	CB83	
97	24V AC/50Hz	CB84	
98	24V AC/50Hz	CB85	
99	24V AC/50Hz	CB86	
100	24V AC/50Hz	CB87	



OZMIST - MIST SYSTEM  
MIST CANNON TRAILER  
3 LINE DIAGRAM  
SHEET 1 OF 3

FOR CONSTRUCTION  
OZM-WAN-01-001-B-0010  
OZM-WAN-01-001-B-0010

NTS  
A3  
2

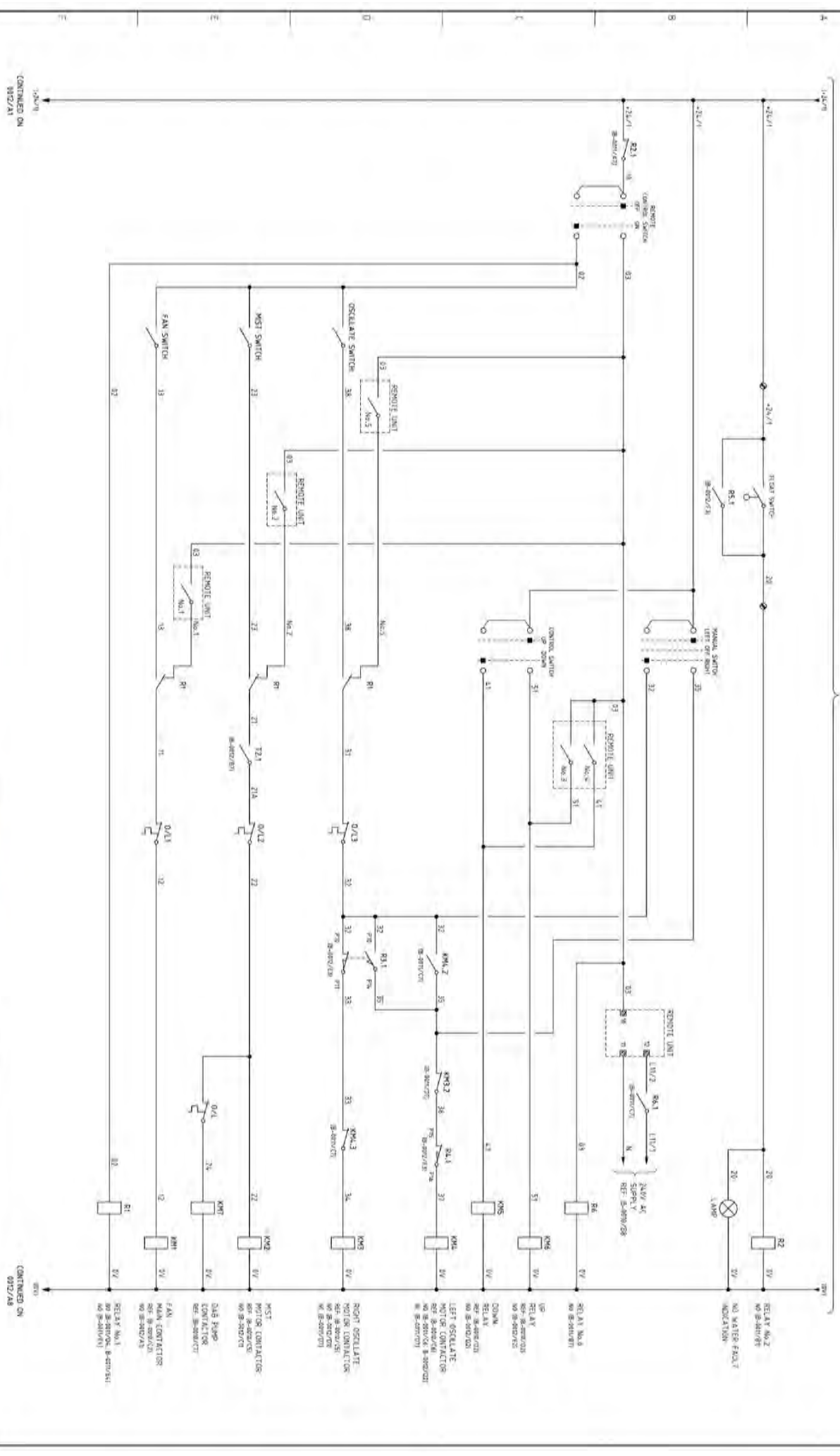

12V/1  
CONTINUED ON  
912/41

24V/1  
CONTINUED ON  
912/48

3	RELAY UNIT REVISED	DATE	BY	CHKD	APP'D	REV	DESCRIPTION
2	RELAY NO.3 & RELAY NO.4 ADDED TO UNIT	24/02/20	MMF	MMF	MMF	1	RELAY NO.3 & RELAY NO.4 ADDED TO UNIT
1	ISSUED FOR CONSTRUCTION	24/01/19	MMF	MMF	MMF	1	ISSUED FOR CONSTRUCTION
0	DRAWN FROM LAMP-03 (E02-02750)	27/08/18	MMF	MMF	MMF	1	DRAWN FROM LAMP-03 (E02-02750)

DATE	BY	CHKD	APP'D
21/02/20	MMF	MMF	MMF
24/01/19	MMF	MMF	MMF
27/08/18	MMF	MMF	MMF

DATE	BY	CHKD	APP'D
21/02/20	MMF	MMF	MMF
24/01/19	MMF	MMF	MMF
27/08/18	MMF	MMF	MMF

DATE	BY	CHKD	APP'D
21/02/20	MMF	MMF	MMF
24/01/19	MMF	MMF	MMF
27/08/18	MMF	MMF	MMF

DATE	BY	CHKD	APP'D
21/02/20	MMF	MMF	MMF
24/01/19	MMF	MMF	MMF
27/08/18	MMF	MMF	MMF

DATE	BY	CHKD	APP'D
21/02/20	MMF	MMF	MMF
24/01/19	MMF	MMF	MMF
27/08/18	MMF	MMF	MMF

DATE	BY	CHKD	APP'D
21/02/20	MMF	MMF	MMF
24/01/19	MMF	MMF	MMF
27/08/18	MMF	MMF </td <td>MMF</td>	MMF



OZMIST - MIST SYSTEM  
MIST CANNON TRAILER  
+24V TDC DISTRIBUTION  
SCHEMATIC DIAGRAM  
SHEET 2 OF 3

FOR CONSTRUCTION  
OZM/MAN-01-001-9-0011  
OZM/MAN-01-001-9-0011

NTS  
A3  
3

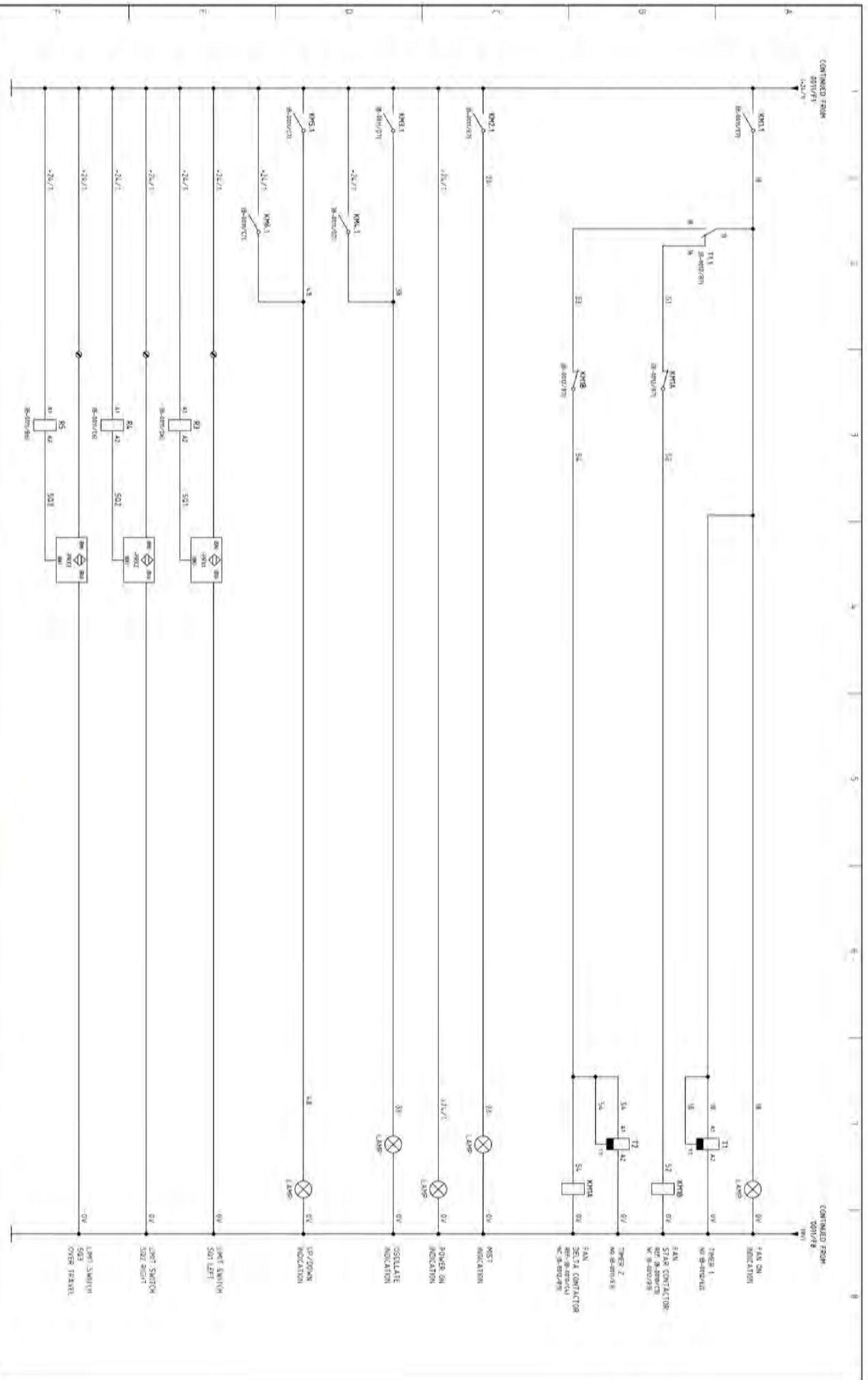

NO.	DESCRIPTION	DATE	BY	CHKD	APP'D	REV	DATE	BY	CHKD	APP'D	REV	DATE	BY	CHKD	APP'D
1	ISSUED FOR CONSTRUCTION	2012.02.20	AMF	AMF	AMF	1	2012.02.20	AMF	AMF	AMF	1	2012.02.20	AMF	AMF	AMF
2	LEFT SWITCH ADDED	2012.02.20	AMF	AMF	AMF	2	2012.02.20	AMF	AMF	AMF	2	2012.02.20	AMF	AMF	AMF
3	CHANGING FROM W/400V TO 200V	2012.02.20	AMF	AMF	AMF	3	2012.02.20	AMF	AMF	AMF	3	2012.02.20	AMF	AMF	AMF

NO.	DESCRIPTION	DATE	BY	CHKD	APP'D
1	ISSUED FOR CONSTRUCTION	2012.02.20	AMF	AMF	AMF
2	LEFT SWITCH ADDED	2012.02.20	AMF	AMF	AMF
3	CHANGING FROM W/400V TO 200V	2012.02.20	AMF	AMF	AMF

NO.	DESCRIPTION	DATE	BY	CHKD	APP'D
1	ISSUED FOR CONSTRUCTION	2012.02.20	AMF	AMF	AMF
2	LEFT SWITCH ADDED	2012.02.20	AMF	AMF	AMF
3	CHANGING FROM W/400V TO 200V	2012.02.20	AMF	AMF	AMF

NO.	DESCRIPTION	DATE	BY	CHKD	APP'D
1	ISSUED FOR CONSTRUCTION	2012.02.20	AMF	AMF	AMF
2	LEFT SWITCH ADDED	2012.02.20	AMF	AMF	AMF
3	CHANGING FROM W/400V TO 200V	2012.02.20	AMF	AMF	AMF



OZMIST - MIST SYSTEM  
MIST CANNON TRAILER  
+241DC DISTRIBUTION  
SCHEMATIC DIAGRAM  
SHEET 3 OF 3

FOR CONSTRUCTION  
SHEET NO. OZM-WAN-01-001-B-0012  
REV. A3  
DATE 2/20/12



Date: 25<sup>th</sup> February 2020  
Revision: 1  
Reference: 250220OzMist

Dean McDonald  
Director  
OzMist

Dear Dean,

Thank you for participating in the Electrical Safety Risk Assessment on the Ozmist Mist Cannon Trailer.

This assessment was required to accurately determine if and what type of Emergency Stop is required.

Results of the risk assessment have determined that no Electrical E-Stop circuit is required if the following mechanical guarding is installed;

**Rack & Pinion**

- New Fixed Guarding to be installed on the most outer ring of the turret to isolate all internal moving parts. Resulting in satisfactory guarding complying with the Australian Standards (AS 4024.1801-2006 – Table 1 safety distances used where a low risk exists)

**4.2.2 Reaching over protective structures**

Figure 2 shows the safety distance for reaching over a protective structure.

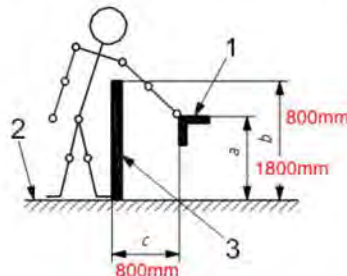

**Key**

- a height of hazard zone 1800mm
- b height of protective structure 800mm
- c horizontal safety distance to hazard zone 800mm
- 1 hazard zone (nearest point)
- 2 reference plane
- 3 protective structure

Table 1 — Reaching over protective structures — Low risk

Dimensions in millimetres

Height of hazard zone <sup>a</sup> <i>h</i>	Height of protective structure <sup>b</sup> <i>h</i>								
	1 000	1 200	1 400	1 600	1 800	2 000	2 200	2 400	2 500
Horizontal safety distance to hazard zone, <i>c</i>									
2 500	0	0	0	0	0	0	0	0	0
2 400	100	100	100	100	100	100	100	100	0
2 200	600	600	500	500	400	350	250	0	0
2 000	1 100	900	700	600	500	350	0	0	0
1 800	1 100	1 000	900	900	600	0	0	0	0
1 600	1 300	1 000	900	900	500	0	0	0	0
1 400	1 300	1 000	900	800	100	0	0	0	0
1 200	1 400	1 000	900	500	0	0	0	0	0
1 000	1 400	1 000	900	300	0	0	0	0	0
800	1 300	900	600	0	0	0	0	0	0
600	1 200	500	0	0	0	0	0	0	0
400	1 200	300	0	0	0	0	0	0	0
200	1 100	200	0	0	0	0	0	0	0
0	1 100	200	0	0	0	0	0	0	0

<sup>a</sup> Protective structures less than 1 000 mm in height are not included because they do not sufficiently restrict movement of the body.

<sup>b</sup> For hazard zones above 2 500 mm, refer to 4.2.1.

For additional information on the risk assessment, List of possible hazards considered, and performance level required scoring. Please refer to the electrical safety risk assessment attached.

## Fan Blades

- 20mm Spacers have been deemed sufficient to increase the safety distance due to the larger sized mesh installed. Noting only an additional 10mm is required to comply with the Australian Standards (AS 4024.1801-2006 – Table 4 Reaching through openings for >14 year old)

**Table 4 — Reaching through regular openings — Persons of 14 years of age and above**

Dimensions in millimetres

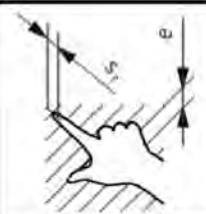
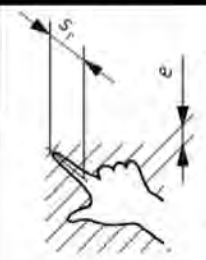
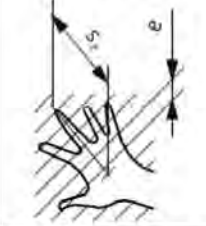
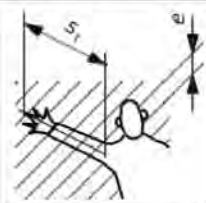
Part of body	Illustration	Opening	Safety distance, $s_r$		
			Slot	Square	Round
Fingertip		$e \leq u \leq 4$	W 2	W 2	W 2
		$4 < e \leq 6$	W 10	W 5	W 5
Finger up to knuckle joint		$6 < e \leq 8$	W 20	W 15	W 5
		$8 < e \leq 10$	W 80	W 25	W 20
		$10 < e \leq 12$	W 100	W 80	W 80
		$12 < e \leq 20$	W 120	W 120	W 120
Hand		$20 < e \leq 30$	W 850 <sup>a</sup>	W 120	W 120
		$30 < e \leq 40$	W 850	W 200	W 120
Arm up to junction with shoulder		$40 < e \leq 120$	W 850	W 850	W 850

The bold lines within the table delineate that part of the body restricted by the opening size.

<sup>a</sup> If the length of the slot opening is  $\leq 65$  mm, the thumb will act as a stop and the safety distance can be reduced to 200 mm.

For additional information on the risk assessment, List of possible hazards considered, and performance level required scoring. Please refer to the electrical safety risk assessment attached.

We have amended your electrical schematics removing the emergency stop contacts and recommend replacing with a black mushroom style (Process Stop).



This will still allow the machine to function as designed by OzMist with no changes to the electrical circuit required on previous or future builds

**Review Undertaken By:**

<b>Name:</b>	<b>Qualifications:</b>	<b>Company:</b>	<b>Date:</b>
Mark Pfeiffer	Director, Functional Safety Trained (TÜV Rheinland)	EDC Electrical	25/02/2020
Darren Stephens	Functional Safety Qualified (TÜV Rheinland)	EDC Electrical	25/02/2020

**Reference Codes, Standards and Publications:**

- Occupational Health and Safety Act 2004
- Vic OH&S regulation 2017
- Electrical Safety (Installations) Regulations 2009 of Victoria
- WorkSafe Plant hazard check list
- AS/NZS 4024 series. 2014 Safety of machinery standards
- AS 3000 – Electrical installations (known as the Australian/New Zealand Wiring Rules)

**Disclaimer**

*This review has been undertaken to identify foreseeable hazards and determine control measures to ensure that obligations under the Vic OH&S Act 2004 are met.*

*Whilst every effort has been made to thoroughly identify foreseeable hazards, determine control measures and assess equipment for compliance with the relevant standards, it should be noted that it remains the responsibility of the designer, manufacture, supplier, installer and business owner to thoroughly assess the design, manufacture and installation for compliance to ensure that all hazards have been adequately controlled to prevent injury.*

*Residual risk needs to be managed as part of equipment ongoing hazard identification and risk assessment and Standard Operating Procedures*

*We also advise that where hazards are identified and not eliminated a risk assessment must be undertaken as soon as possible in consultation with employees and in accordance with the Vic OH&S Act 2004*

Yours Faithfully



Mark Pfeiffer

Mobile: +61 417 366 207

Phone: +61 2 6024 6044

Fax: +61 2 6024 6055

Email: [markpfeiffer@edcelectrical.com.au](mailto:markpfeiffer@edcelectrical.com.au)

Website: [www.edcelectrical.com.au](http://www.edcelectrical.com.au)



**MACHINE SAFETY INSPECTION & TEST PLAN**  
**OZMIST**  
**MIST CANNON ELECTRICAL RISK ASSESSMENT PROCESS**

<b>ITP NUMBER</b>	J23055.ITP.011
<b>DATE</b>	25/02/2020
<b>REV</b>	1

<b>PROJECT</b>	Mist Cannon	<b>LOCATION</b>	EDC Workshop	<b>PREPARED BY</b>	Mark Pfeiffer	<b>REVIEWED BY</b>	Darren Stephens
<b>REV NO</b>	1	<b>BUILDING / AREA</b>		<b>DATE</b>	25/02/2019	<b>APPROVED BY</b>	
<b>CLIENT</b>	OZMist						

**LEGEND**

<b>R</b>	Risk Assessment	Overall process comprising a risk analysis and a risk evaluation
<b>PLE</b>	Performance Level Evaluation	Performance level applied in order to achieve the required risk reduction for each safety function
<b>MSD-E</b>	Machine Safety Design Electrical	Electrical equipment designed and installed, to meet both the functional and performance requirements of the safety functions
<b>MSD-M</b>	Machine Safety Design Mechanical	Mechanical works for safeguarding and complementary protective measures
<b>SAT-E</b>	Site Acceptance Test Electrical	Electrical test activity to be undertaken and recorded
<b>SAT-M</b>	Site Acceptance Test Mechanical	Mechanical test activity to be undertaken and recorded
<b>H</b>	Hold Point	Work shall not proceed past the hold point until released by the organization imposing the Hold point
<b>RV</b>	Review	Review of reports or other evidence of compliance

**REFERENCE DOCUMENTS**

**Development:**  
Electrical Safety Risk Assessment

**Implementation:**  
N/A







**APPROVAL/REVISION**

Rev	Date	Details	Approved by	Date
1	25.02.2020	Assessment Completed	Mark Pfeiffer & Darren Stephens	25.02.2020



**MACHINE SAFETY INSPECTION & TEST PLAN**  
**OZMIST**  
**MIST CANNON ELECTRICAL RISK ASSESSMENT PROCESS**

<b>ITP NUMBER</b>	J23055.ITP.011
<b>DATE</b>	25/02/2020
<b>REV</b>	1

Item No.	Activity / Basic Job Step	Responsible	Acceptance Criteria	Applicable Standard	Verification By			Verifying Records / Checklists
					Name / Position	Signature	Date	
1	Risk Assessment	EDC	All Electrical hazards identified & Risk assessment completed	AS/NZS 4024.1201.2014	Mark Pfeiffer Electrical Design  Darren Stephens Functional Safety Qualified (TUV Rheinland)	 	25.02.2020	
2	Performance Level Evaluation	EDC	Identify the safety related parts which carry out the safety function	AS/NZS 4024.1503:2014	Mark Pfeiffer Electrical Design  Darren Stephens Functional Safety Qualified (TUV Rheinland)	 	25.02.2020	
3	Machine Safety Design Electrical	EDC	Completed design of the safety related parts of a control system	AS/NZS 4024.1501:2014	Mark Pfeiffer Electrical Design  Darren Stephens Functional Safety Qualified (TUV Rheinland)	 	25.02.2020 25.02.20	
4	Machine Safety Design Mechanical	OZMIST	Completed design of the safeguarding and complementary protective measures					
5	Site Acceptance Test Electrical	EDC	Demonstrated and documented that each safety related part meets the requirements of AS 4024.1501	AS/NZS 4024.1502:2014	Not Required	Not Required	Not Required	Not Required

**Note: Once each stage of the job is completed please sign under the Verification Activity, include name / position and also date when the final task was completed for that line item.**

# ELECTRICAL SAFETY RISK ASSESSMENT

*for*

Client: Ozmist  
Site Location: EDC Workshop  
Reference:  
Plant / Equipment Location: Transportable  
Plant / Equipment Details: Misting Fan (Application Dust Suppression)  
Asset Number: N/A  
Assessment Requirement:

EDC Representatives : Mark Pfeiffer  
Darren Stephens  
Client Representatives: Dean McDonald

Date Of Assessment: 25.02.2020

Date : 25.02.2020

Report No :  
Rev : 1.0



Client:	Ozmist	
Location:	EDC Workshop	
Equipment Loc:	Transportable	
Equipment Detail:	Misting Fan (Application Dust Suppression)	
Asset Number:	N/A	

## 1.0 Reference Standards

Reference	Standards Title
AS/NZS4024.1-2014	Safety of Machinery: Series 1 Australian/ New Zealand Standard
AS4024.2801-2008	AS4024.2801-2008 Safeguarding of Machinery – Installation and commissioning requirements
AS 60204-1:2006	Safety of machinery - Electrical equipment of machines - Part 1: General requirements (IEC 60204-1:2009-02)

## 2.0 Plant & Machinery Hazard Analysis

The initial stage of Risk Assessment is concerned with the identification of the hazards. In the case of new machinery in the design stage, it may be possible to identify a hazard and conduct a redesign to reduce or eliminate the risks. In the case of existing machinery, this option is rarely possible. The options from this point are to provide protective measures. These usually involve the provision of a combination of fixed and distance guarding.

The lists below provide examples of possible hazards which may exist on plant/machinery and a list of recommended control measures which may be implemented to mitigate or eliminate the hazards.

### List of Possible Hazards

None Identified  
 Mech - Crush hazard from falling material  
 Mech - Crush hazard on Loading System  
 Mech - Conveyor/Roller; Nip/Pinch Point  
 Mech - Automatic Cycle / Unexpected Start  
 Mech - Cut hazard on blades/ Machine Parts  
 Mech - Plant tipping or rolling over  
 Mech - Being trapped between plant or fixed structures  
 Mech - Suspended Live Load  
 Control Sys - Safety Control Category  
 Control Sys - Fail to Stop  
 Control Sys - Defeated/Jumpered Safeguard Devices  
 Control Sys - Automatic Cycle / Unexpected Start  
 Control Sys - Jogging / Unlimited Speed  
 Control Sys - Electric Shock  
 Multiple hazards in emergency situations  
 Electrical - Improper Grounding  
 Electrical - Live parts  
 Electrical - Flash  
 Electrical - Water ingress  
 Pneumatic - Safety Control Category  
 Pneumatic - Overpressure  
 Coming in contact with sharp or flying objects  
 The plant (parts of) or work pieces disintegrating  
 Ejection of work pieces from plant  
 Uncontrolled or unexpected movement of the plant  
 The mobility of the plant  
 Entrapment in cell during full body access  
 Hydraulic - Overpressure  
 Pressure Vessel  
 Slip / Trip / Fall  
 Temperature / Burn  
 Temperature from friction of moving parts  
 Hot / Boiling liquids  
 Chemical / Fumes  
 Ergonomics  
 Fire / Explosion  
 Noise  
 Other factors not mentioned

### List of Recommended Control Measures

None Present / Client Responsibility  
 Administrative Controls / PPE  
 Fixed Guard: Replace / Repair existing and/or Fasteners  
 Fixed Guarding: Add new and/or Fasteners  
 Fixed Guard: High level/platform guarding and gate  
 Fixed Guard, Polycarbonate: Replace existing  
 Fixed Guard, Polycarbonate: Add New  
 Movable Guarding/Gate: Replace / Repair existing and/or Fasteners  
 Movable Guarding/Gate: Add new, Interlocked  
 Conveyor Underside Guarding: Add new  
 Conveyor Underside Guarding: Add new, Interlocked  
 Zone Control: Define/create and guard Safety Zones  
 Zone Control: Relocate existing controls outside of Safety Zones  
 E-Stops Upgrade: Replace with compliant E-Stop PB & Safety Reset  
 E-Stops: Install new Emergency Stop  
 E-Stops: Install new Pull-cord/Lanyard  
 Upgrade Safety Controls: PLR Safety-rated components  
 Access Control: Add non-locking Gate Switch  
 Access Control: Add Gate Locking Switch  
 Access Control: Add Trapped Key Switch  
 Access Control: Add Enabling Switch  
 Access Control: Two-Hand Controls  
 Presence Sensing: Add Light Curtain  
 Presence Sensing: Add Safety Mat  
 Presence Sensing: Add Edge Detector  
 Presence Sensing: Add Laser Scanner  
 Pressure Control/Monitoring: Add pressure switch to safety circuit  
 Temperature Control/Monitoring: include in safety circuit  
 Safe/Zero Speed: Add Speed Sensing relays/controls for safe access  
 Safe/Zero Speed: Add control reliable circuits for safe access  
 Pneumatic Isolation: safety contactor/relay only  
 Pneumatic Isolation: safety contactor/relay pair  
 Pneumatic Isolation: safety valve; block/bleed  
 Hydraulic Isolation: safety contactor/relay only  
 Hydraulic Isolation: safety contactor/relay pair  
 Hydraulic Isolation: safety valve; block/bleed  
 Hydraulic Isolation: Add Hose Burst protection  
 Mechanical: Add mechanical stop to prevent machine movement  
 Other factors not mentioned



Client:	Ozmist
Location:	EDC Workshop
Equipment Loc:	Transportable
Equipment Detail:	Misting Fan (Application Dust Suppression)
Asset Number:	N/A



### 3.0 Risk Estimation & Evaluation Criteria

In order to identify, estimate and reduce the hazards present in machinery a Preliminary Hazard Analysis is performed using Hazard Rating Number (HRN). Using this technique, it is possible to assign a number to a specific risk with higher numbers representing greater risks. Risk is generally described in AS/NZS 4024.1201:2014 (EN 12100) as a function of : frequency of exposure, severity of harm, number of persons exposed & the likelihood of occurrence.

The four parameters are evaluated in the HRN process:  $HRN = FE \times DPH \times NP \times LO$

#### Frequency of Exposure (FE)

0.5	Annually
1	Monthly
1.5	Weekly
2.5	Daily
4	Hourly
5	Constantly

#### Degree of Possible Harm (DPH)

0.1	Scratch / Bruise
0.5	Burn, cut, short illness
2	Fracture: minor bone or minor illness (temporary)
4	Fracture: major bone or major illness (temporary)
6	Amputation of a limb, one eye or partial hearing loss
10	Amputation of two limbs, eyes or total loss of hearing or sight
15	Fatality

#### Number of Persons at Risk (NP)

1	1- 2 persons
2	3 - 7 persons
4	8 - 15 persons
8	16 - 50 persons
12	More than 50 persons

#### Likelihood of Occurrence (LO)

0.033	Little/low possibility, extreme circumstances
1	Highly improbable, but still possible
1.5	Improbable, but still possible
2	Possible, but unusual
5	Although improbable, it may happen
8	Probable – Not surprising
10	Probable – Can be expected
15	Certain – No doubt

HRN	Risk	Comment
0-4.9	Negligible Risk	Presents very little risk to health and safety. The residual risks are to be controlled by awareness training and in some cases by warning signs.
5 – 49.9	Low but significant risk	These are risks that need to be reduced by applying suitable control measures but are not considered urgent
50-499.9	High risk	Having potentially dangerous hazards, which require control measures to be implemented urgently
500 >	Unacceptable Risk	These hazards are extreme and the equipment should not be operated until the level has been reduced.

### 4.0 Selection of Performance level required (PLr)

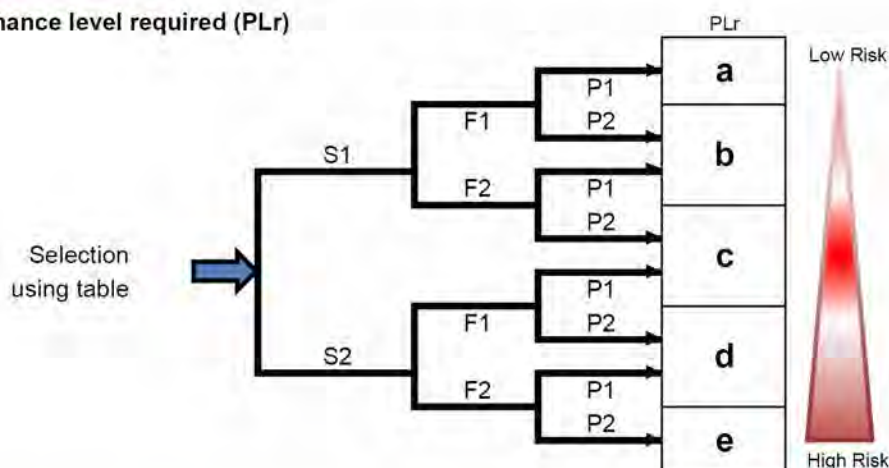

S	Severity of injury	Description
S1	slight (normally reversible injury)	bruise, abrasion, puncture wound, minor injury
S2	serious (non-reversible injury or death)	skeletal injuries, amputations and death
F	Frequency and/or exposure to hazard	
F1	seldom to less often and/or exposure time is short	less frequently than every two weeks
F2	frequent to continuous or exposure time is long	more often than every two weeks



Client:	Ozmist
Location:	EDC Workshop
Equipment Loc:	Transportable
Equipment Detail:	Misting Fan (Application Dust Suppression)
Asset Number:	N/A



P	Possibility of avoiding hazard or harm	
P1	possible under specific conditions	slow movements, plenty of space, low power
P2	scarcely possible	quick machine movements, crowded, high power

Client:	Ozmist
Location:	EDC Workshop
Equipment Loc:	Transportable
Equipment Detail:	Misting Fan (Application Dust Suppression)
Asset Number:	N/A

HRN	Risk
0-5	Negligible
6-50	Low significant
51-500	High
> 500	Unacceptable

**A. ENTANGLEMENT**  
 Can anyone's hair, clothing, gloves, necktie, jewellery, cleaning brushes, rags or other materials become entangled with moving parts of the Plant, or materials in motion?  
 Assess Risk With No Safeguards To Determine Category Rating Required  
 No safeguards (determine PL requirements)

ITEM #	PICTURE REF #	Possible Hazard	Exists Y / N	Machine Task / Comments	Existing / Recommended Control Measures	Likelihood of Occurrence (LO)	Freq of Exposure (FE)	Degree of Possible Harm (DPH)	No. Persons Exposed (NP)	Mech Guards Present Yes / No	Hazard Rating Number	Risk Level	S	F	P	Cat	PL
A-1	3	Loose clothing getting caught in the rack & Pinion assembly	Yes	Set-up / Changeover	Administrative Controls / PPE	Improbable but still possible (1.5)	Daily (2.5)	Break Minor bone or minor illness (temporary) (2)	1-2 persons (1)	No	7.5	Low but significant	S1	F1	P1	B	a
A-2	1	Long hair getting sucked into the fan causing entanglement.	Yes	Normal Operation	Administrative Controls / PPE	Improbable but still possible (1.5)	Daily (2.5)	Break Major Bone or Major illness (temporary) (4)	1-2 persons (1)	Yes	15	Low but significant					
A-3																	P1
A-4																	P1

**NOTES**

Hair & Correct use of PPE to be incorporated into the user manual.  
 Hair to be neat and tidy with any considerable length the be contained to ensure hair cannot be sucked into fan causing entanglement.

**Description of recommended Control Measures**

After Hazop the following corrective measures were discussed to remove the Hazard  
 - Install Guarding on the turret. Guarding to be installed on the outer most ring to isolate all internal moving parts.

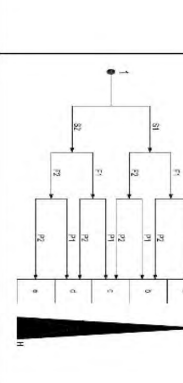

Client:	Ozmist		HRN	Risk	HRN = LO x FE x DPH x NP (determination of P/R requirements)
Location:	EDC Workshop		0-5	Negligible	
Equipment Loc:	Transportable		6-50	Low, significant	
Equipment Detail:	Misting Fan (Application Dust Suppression)		51-500	High	
Asset Number:	N/A	> 500	Unacceptable		

ITEM #	PICTURE REF #	Possible Hazard	Exists Y / N	Comments / Task	Existing / Recommended Control Measures	Likelihood of Occurrence (LO)	Freq of Exposure (FE)	Degree of Possible Harm (DPH)	No. Persons Exposed (NP)	Mechanical Guarding Yes/No	Hazard Rating Number	Risk Level	S	F	P	Cat	PIR	
B-1	2	Crushing of fingers when lowering the machinery into home position	Yes	Set-up / Changeover	Administrative Controls / PPE	Highly unlikely - though conceivable (1)	Daily (2.5)	Break Minor bone or minor illness (temporary) (2)	1-2 persons (1)	No	5	Negligible	S1	F1	P1	B	a	
B-2																		
B-3																		

NOTES																	
Description of recommended Control Measures																	
Recommend adding to safe operating procedure: Operator can only attempt to remove / insert the pin when the machine is turned off. Thus eliminating the crushing hazard.																	



Pic 1



Pic 2

Pic 4

Pic 5

Pic 6

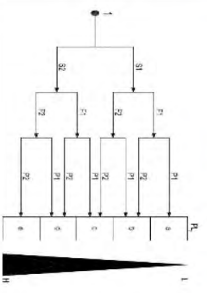





HRN	Risk
0-5	Negligible
6-50	Low significant
51-500	High
> 500	Insupportable

**C. CUTTING, STABBING AND PUNCTURING**  
Can anyone be cut, stabbed or punctured due to:

ITEM #	PICTURE REF #	Possible Hazard	Exists Y / N	Comments / Task	Existing / Recommended Control Measures	Likelihood of Occurrence (LO)	Freq of Exposure (FE)	Degree of Possible Harm (DPH)	No. Persons Exposed (NP)	Meat Guards Present (Yes No)	Hazard Rating Number	Risk Level	\$	F	P	Cd	Ru
C-1	2	Fingers Coming in contact with sharp or flying objects	Yes	Normal Operation	Fixed Guarding Add new and/or Fasteners	Highly unlikely - though conceivable (1)	Daily (2.5)	Laceration / mild ill-effect (0.5)	1-2 persons (1)	Yes	1.25	Negligible					P1
C-2																	P1
C-3																	P2

**NOTES**

**Description of recommended Control Measures**

After hazard the following corrective measures were discussed to remove the Hazard  
 - Guarding on the back of the fan is unsatisfactory. Additional 20mm spacers to be installed between fan housing and mesh Guarding to be installed to comply with Table 1 (AS4024:1801-2006, Safety Distances used where a low risk exists).

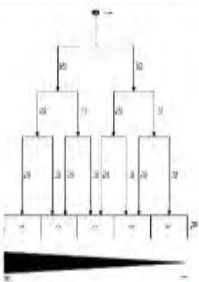



Client:	Ozminst		<table border="1"> <tr> <th>HRN</th> <th>Risk</th> </tr> <tr> <td>0-5</td> <td style="background-color: #90EE90;">Negligible</td> </tr> <tr> <td>6-50</td> <td style="background-color: #FFD700;">Low, significant</td> </tr> <tr> <td>51-500</td> <td style="background-color: #FF4500;">High</td> </tr> <tr> <td>&gt; 500</td> <td style="background-color: #FF0000;">Unacceptable</td> </tr> </table>	HRN	Risk	0-5	Negligible	6-50	Low, significant	51-500	High	> 500	Unacceptable
HRN	Risk												
0-5	Negligible												
6-50	Low, significant												
51-500	High												
> 500	Unacceptable												
Location:	EDC Workshop												
Equipment Loc:	Transportable												
Equipment Detail:	Misting Fan (Application Dust Suppression)												
Asset Number:	N/A		HRN = LO x FE x DPH x NP										

**D. SHEARING**  
Can anyone's body parts be sheared due to:

ITEM #	PICTURE REF #	Possible Hazard	Exists Y / N	Comments / Task	Existing / Recommended Control Measures	Likelihood of Occurrence (LO)	Freq of Exposure (FE)	Degree of Possible Harm (DPH)	No. Persons Exposed (NP)	Mechanical Guarding Yes/No	Hazard Rating Number	Risk Level	S	F	P	Call	PLR	
D-1	2	Placing fingers & hand into rotating assembly while operating with fingers getting caught between striker plate and proximities switches	Yes	Normal Operation	E-Stops Upgrade. Replace with compliant E-Stop PB & Safety Reset	Highly unlikely - though conceivable (1)	Daily (2.5)	Laceration / mild ill-effect (0.5)	1-2 persons (1)	No	1.25	Negligible	S1	F1	P1	B	<b>a</b>	
D-2																	P1	
D-3																	P2	

**NOTES**

After Hazop the following corrective measures were discussed to remove the Hazard  
 - Install Guarding on the turret. Guarding to be installed on the outer most ring to isolate all internal moving parts.



Pic 1



Pic 2



Pic 4

Pic 5

Pic 6

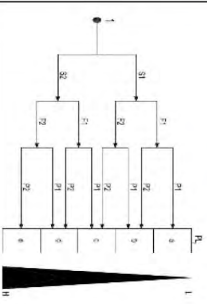

Client:	Qznist		<table border="1"> <tr> <th>HRN</th> <th>Risk</th> </tr> <tr> <td>0-5</td> <td>Negligible</td> </tr> <tr> <td>6-50</td> <td>Low/ significant</td> </tr> <tr> <td>51-500</td> <td>High</td> </tr> <tr> <td>&gt; 500</td> <td>Unacceptable</td> </tr> </table>	HRN	Risk	0-5	Negligible	6-50	Low/ significant	51-500	High	> 500	Unacceptable
HRN	Risk												
0-5	Negligible												
6-50	Low/ significant												
51-500	High												
> 500	Unacceptable												
Location:	EDC Workshop												
Equipment Loc:	Transportable												
Equipment Detail:	Misting Fan (Application Dust Suppression)												
Asset Number:	N/A		HRN = LO x FE x DPH x NF										

**E. STRIKING**  
Can anyone be struck by moving objects due to:

ITEM #	PICTURE REF #	Possible Hazard	Exists Y/N	Comments / Task	Existing / Recommended Control Measures	Likelihood of Occurrence (LO)	Freq of Exposure (FE)	Degree of Possible Harm (DPH)	No. Persons Exposed (NP)	Mechanical Guarding Yes/No	Hazard Rating Number	Risk Level	S	F	P	Cal	PLr
E-1	1	Ejection of work pieces from plant	Yes	Normal Operation	E-Stops Upgrade; Replace with compliant E-Stop PB & Safety Reset	Almost impossible - possible only under extreme circumstances (0.033)	Daily (2.5)	Laceration / mild ill-effect (0.5)	1-2 persons (1)	No	0.04125	Negligible	S1	F1	P1	B	<b>a</b>
E-2																	P1
E-3																	P2

**NOTES**

**Description of recommended Control Measures**

Recommend adding to safe operating procedure. All Personnel working in the vicinity are required to maintain appropriate PPE

<p><b>NOTES</b></p> <p>Recommend adding to safe operating procedure. All Personnel working in the vicinity are required to maintain appropriate PPE</p>																
---	--	--	--	--	--	--	--	--	--	--	--	--	--	--	--	--

Pic 1



Pic 2



Pic 3

Pic 4

Pic 5

Pic 6

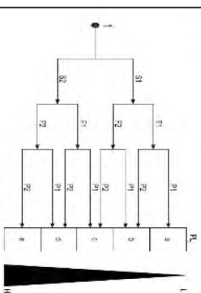



Client:	Oznist		<table border="1"> <tr> <th>HIRN</th> <th>Risk</th> </tr> <tr> <td>0-5</td> <td>Negligible</td> </tr> <tr> <td>6-50</td> <td>Low, significant</td> </tr> <tr> <td>51-500</td> <td>High</td> </tr> <tr> <td>&gt; 500</td> <td>Unacceptable</td> </tr> </table>	HIRN	Risk	0-5	Negligible	6-50	Low, significant	51-500	High	> 500	Unacceptable
HIRN	Risk												
0-5	Negligible												
6-50	Low, significant												
51-500	High												
> 500	Unacceptable												
Location:	EDC Workshop												
Equipment Loc:	Transportable												
Equipment Detail:	Misting Fan (Application Dust Suppression)												
Asset Number:	N/A	$HIRN = LO \times FE \times DPH \times NF$											

**F. TEMPERATURE**  
 Can anyone be burnt due to contact with :

ITEM #	PICTURE REF #	Possible Hazard	Exists Y / N	Comments / Task	Existing / Recommended Control Measures	Assess Risk With No Safeguards To Determine Category Rating Required						Risk Level	S	F	P	Ca	PLr	
						Likelihood of Occurrence (LO)	Freq of Exposure (FE)	Degree of Possible Harm (DPH)	No. Persons Exposed (NP)	Mechanical Guarding Yes/No	Hazard Rating Number							
F-1		None Identified																P1
F-2																		P1
F-3																		P2

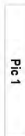
NOTES																
Description of recommended Control Measures																

 Pic 1

 Pic 2

 Pic 3

 Pic 4

 Pic 5

 Pic 6

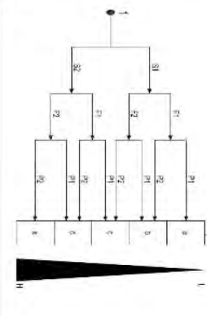



Client:	Orniet
Location:	EDC Workshop
Equipment Loc:	Transportable
Equipment Detail:	Misting Fan (Application Dust Suppression)
Asset Number:	N/A

HRN	Risk
0-5	Negligible
6-50	Low significant
51-500	High
> 500	Unacceptable

HRN = LO X FE X DPH X NF  
No safeguards (determination of PL requirements)

**G. HIGH PRESSURE**  
Can persons come into contact with High Pressure from :

ITEM #	PICTURE REF #	Possible Hazard	Exists Y / N	Comments / Task	Existing / Recommended Control Measures	Likelihood of Occurrence (LO)	Freq of Exposure (FE)	Degree of Possible Harm (DPH)	No. Persons Exposed (NP)	Mechanical Guarding Yes / No	Hazard Rating Number	Risk Level	S	F	P	Call	PL		
G-1		None Identified																P2	
G-2																			P1
G-3																			P2

**NOTES**

Description of recommended Control Measures

Pic 1

Pic 2

Pic 3

Pic 4

Pic 5

Pic 6

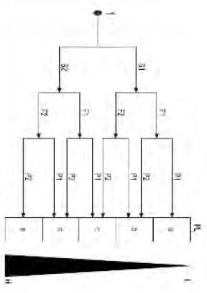



Client:	Ornlist		HRN	Risk	No safeguards (determination of 'Lr' requirements) $HRN = LO \times FE \times DPH \times NE$
Location:	EDC Workshop		0-5	Negligible	
Equipment Loc:	Transportable		6-50	Low/ significant	
Equipment Detail:	Misting Fan (Application Dust Suppression)		51-500	High	
Asset Number:	N/A	> 500	Unacceptable		

**H. ELECTRICAL**  
Can anyone be injured by electrical shock or burnt due to:

ITEM #	PICTURE REF #	Possible Hazard	Exists Y/N	Comments / Task	Existing / Recommended Control Measures	Assess Risk With No Safeguards To Determine Category Rating Required						Risk Level	S	F	P	Call P/Lr
						Likelihood of Occurrence (LO)	Freq of Exposure (FE)	Degree of Possible Harm (DPH)	No. Persons Exposed (NP)	Mechanical Guarding Yes/No	Hazard Rating Number					
H-1		None Identified														P2
H-2																P1
H-3																P2

**NOTES**  
Description of recommended Control Measures

	Pic 1	Pic 2	Pic 3	Pic 4	Pic 5	Pic 6
--	-------	-------	-------	-------	-------	-------

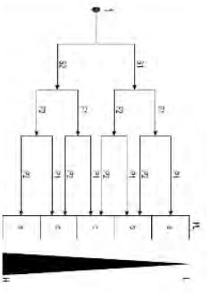

Client:	Ozmist		<table border="1"> <tr> <th>HRN</th> <th>Risk</th> </tr> <tr> <td>0-5</td> <td>Negligible</td> </tr> <tr> <td>6-50</td> <td>Low, significant</td> </tr> <tr> <td>51-500</td> <td>High</td> </tr> <tr> <td>&gt; 500</td> <td>Unacceptable</td> </tr> </table>	HRN	Risk	0-5	Negligible	6-50	Low, significant	51-500	High	> 500	Unacceptable
HRN	Risk												
0-5	Negligible												
6-50	Low, significant												
51-500	High												
> 500	Unacceptable												
Location:	EDC Workshop												
Equipment Loc:	Transportable												
Equipment Detail:	Misting Fan (Application Dust Suppression)												
Asset Number:	N/A	HRN = LO x FE x DPH x NF											

**1. EXPLOSION**  
Can anyone be injured by explosion of :

ITEM #	PICTURE REF #	Possible Hazard	Exists Y / N	Comments / Task	Existing / Recommended Control Measures	Likelihood of Occurrence (LO)	Freq of Exposure (FE)	Degree of Possible Harm (DPH)	No. Persons Exposed (NP)	Mechanical Guarding Yes/No	Hazard Rating Number	Risk Level	S	F	P	Cat	PLT	
I-1		None Identified																
I-2																		P1
I-3																		P2

**NOTES**

**Description of recommended Control Measures**

																	
---	--	--	--	--	--	--	--	--	--	--	--	--	--	--	--	--	--

